

AMMST2907A-HF (PNP)

RoHS Device
Halogen Free

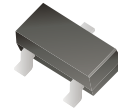

Features

- Epoxy meets UL-94 V-0 flammability rating.
- Moisture sensitivity Level 1.
- High conductance.
- AEC-Q101 Qualified.

Mechanical data

- Case: SOT-323, molded plastic.
- Terminals: Tin plated leads, solderable per J-STD-002 and JESD22-B102.

Circuit Diagram

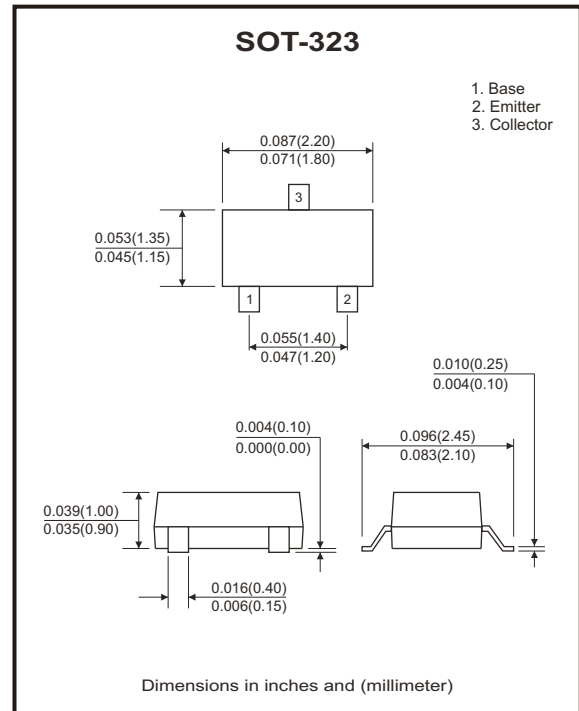
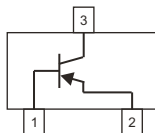

Maximum Ratings (at Ta=25°C unless otherwise noted)

Parameter	Symbol	Value	Unit
Collector-base voltage	V_{CBO}	-60	V
Collector-emitter voltage	V_{CEO}	-60	V
Emitter-base voltage	V_{EBO}	-5	V
Collector current-continuous	I_C	-600	mA
Total device dissipation	P_D	200	mW
Thermal resistance junction to ambient	$R_{\theta JA}$	625	K/W
Junction temperature range	T_J	-55 ~ +150	°C
Storage temperature range	T_{STG}	-55 ~ +150	°C

Electrical Characteristics (at Ta=25°C unless otherwise noted)

Parameter	Conditions	Symbol	Min	Max	Unit
Collector-emitter breakdown voltage	$I_C = -10\text{mA}, I_B = 0$	$V_{(BR)CEO}$	-60		V
Collector-base breakdown voltage	$I_C = -10\mu\text{A}, I_E = 0$	$V_{(BR)CBO}$	-60		V
Emitter-base breakdown voltage	$I_E = -10\mu\text{A}, I_C = 0$	$V_{(BR)EBO}$	-5		V
Collector cut-off current	$V_{CE} = -30\text{V}, V_{EB} = -0.5\text{V}$	I_{CEX}		-50	nA
Collector cut-off current	$V_{CB} = -50\text{V}, I_E = 0$	I_{CBO}		-20	nA
DC current gain	$V_{CE} = -10\text{V}, I_C = -0.1\text{mA}$	$h_{FE(1)}$	75		
	$V_{CE} = -10\text{V}, I_C = -1\text{mA}$	$h_{FE(2)}$	100		
	$V_{CE} = -10\text{V}, I_C = -10\text{mA}$	$h_{FE(3)}$	100		
	$V_{CE} = -10\text{V}, I_C = -150\text{mA}$	$h_{FE(4)}$	100	300	
	$V_{CE} = -10\text{V}, I_C = -500\text{mA}$	$h_{FE(5)}$	50		
Collector-emitter saturation voltage	$I_C = -150\text{mA}, I_B = -15\text{mA}$ $I_C = -500\text{mA}, I_B = -50\text{mA}$	$V_{CE(sat)}$		-0.4 -1.6	V
Base-emitter saturation voltage	$I_C = -150\text{mA}, I_B = -15\text{mA}$ $I_C = -500\text{mA}, I_B = -50\text{mA}$	$V_{BE(sat)}$		-1.3 -2.6	V
Transition frequency	$V_{CE} = -20\text{V}, I_C = -50\text{mA}, f = 100\text{MHz}$	f_T	200		MHz
Delay time	$V_{CC} = -30\text{V},$	t_d		10	ns
Rise time	$I_C = -150\text{mA}, I_{B1} = -15\text{mA}$	t_r		40	ns
Storage time	$V_{CC} = -6\text{V}, I_C = -150\text{mA}$	t_s		225	ns
Fall time	$I_{B1} = I_{B2} = -15\text{mA}$	t_f		60	ns

Rating and Characteristic Curves (AMMST2907A-HF)

Fig.1 - Collector Saturation Region

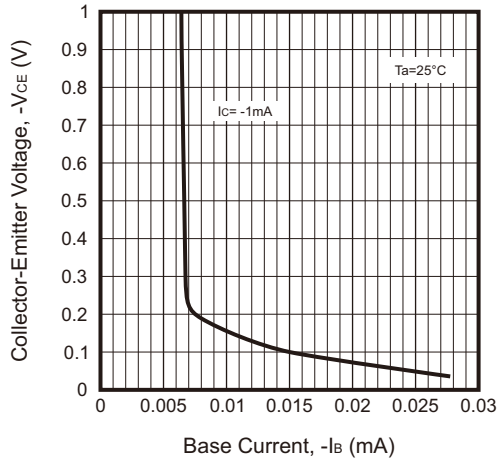

Fig.2 - Collector Saturation Region

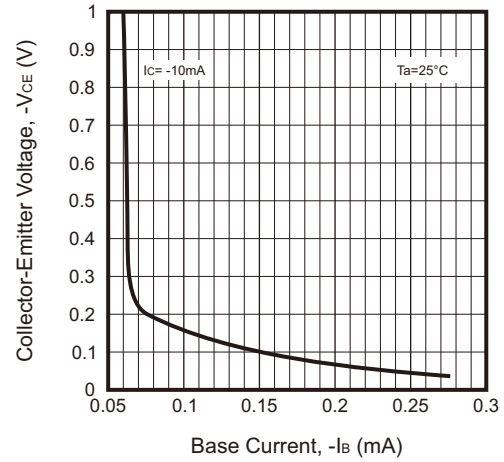

Fig.3 - Collector Saturation Region

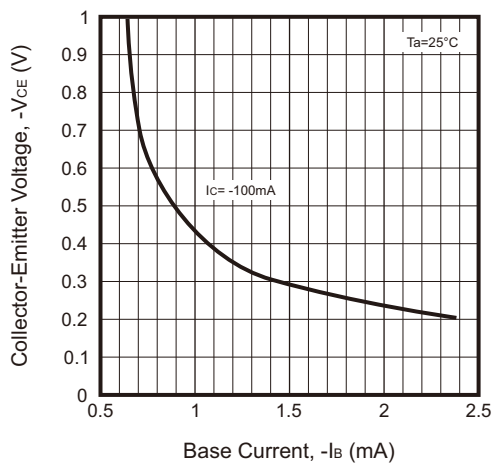

Fig.4 - DC Current Gain

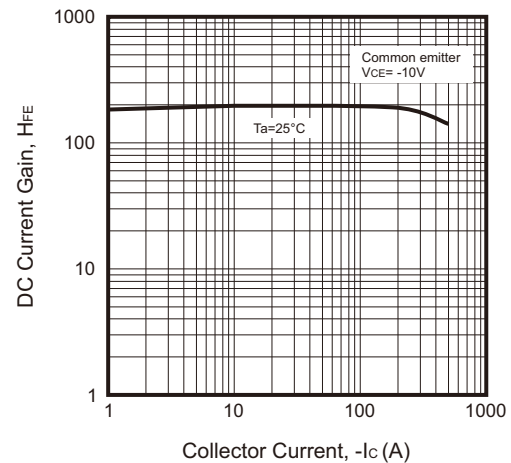

Fig.5 - Base-Emitter Saturation Voltage vs. Collector Current

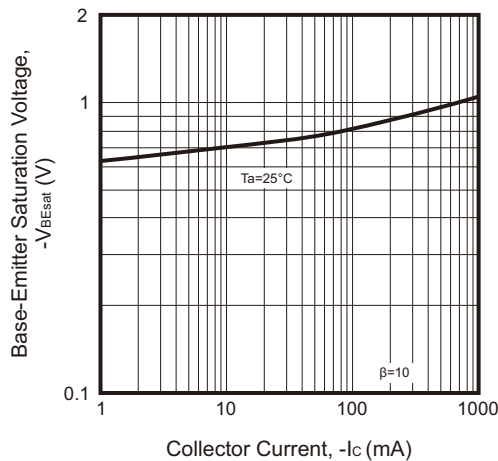
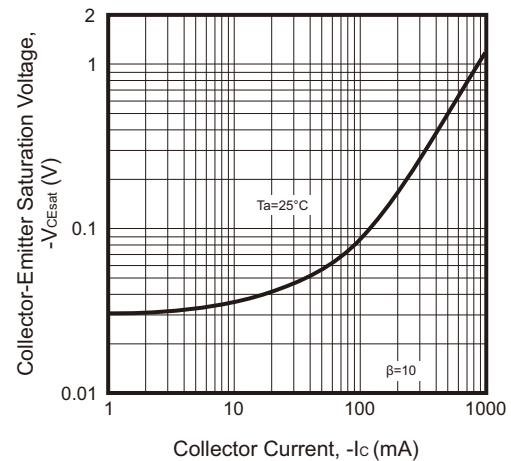
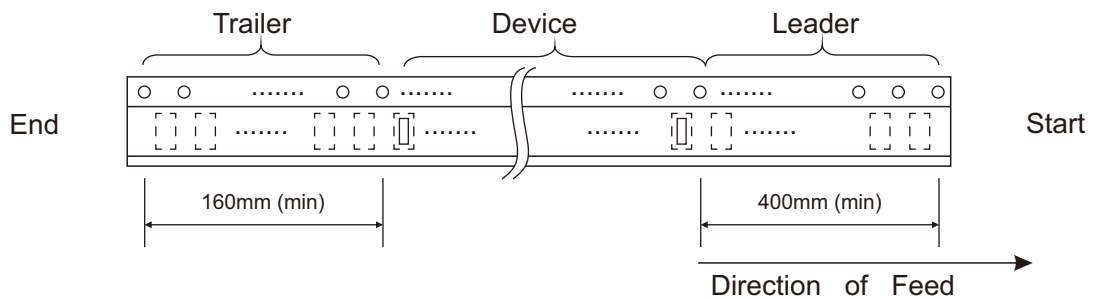
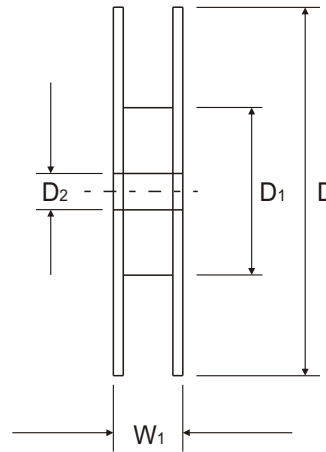
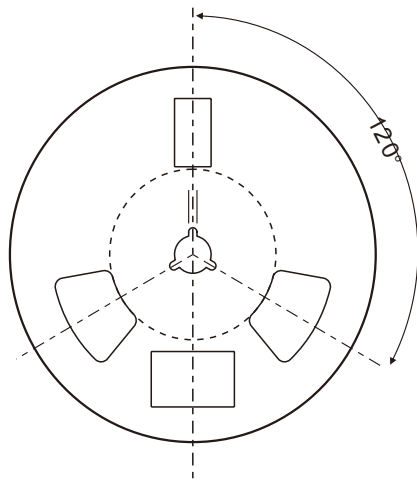
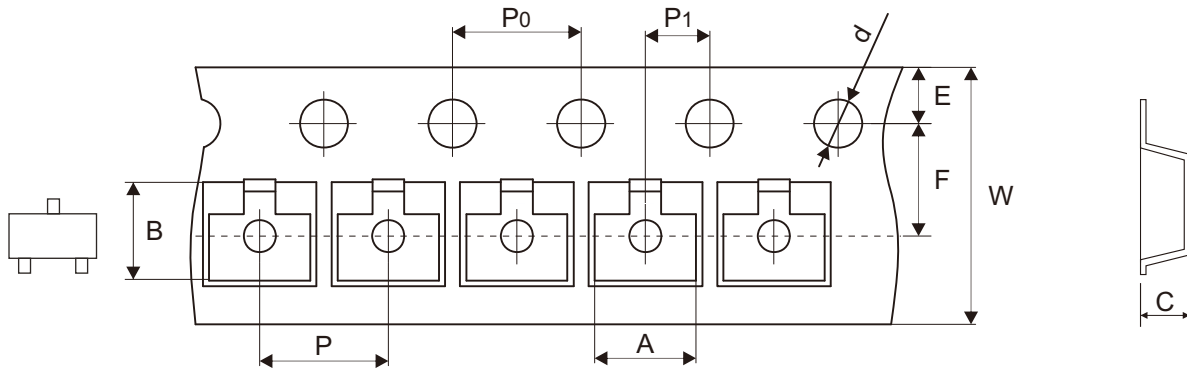

Fig.6 - Collector-Emitter Saturation Voltage vs. Collector Current



Company reserves the right to improve product design, functions and reliability without notice.

Reel Taping Specification



SOT-323	SYMBOL	A	B	C	d	D	D1	D2
	(mm)	2.25 ± 0.10	2.55 ± 0.10	1.19 ± 0.10	1.50 ± 0.10	178.00 ± 2.00	54.40 ± 1.00	13.00 ± 1.00
	(inch)	0.089 ± 0.004	0.100 ± 0.004	0.047 ± 0.004	0.059 ± 0.004	7.008 ± 0.079	2.142 ± 0.039	0.512 ± 0.039

SOT-323	SYMBOL	E	F	P	P0	P1	W	W1
	(mm)	1.75 ± 0.10	3.50 ± 0.05	4.00 ± 0.10	4.00 ± 0.10	2.00 ± 0.05	8.00 + 0.30 - 0.10	12.30 ± 1.00
	(inch)	0.069 ± 0.004	0.138 ± 0.002	0.157 ± 0.004	0.157 ± 0.004	0.079 ± 0.002	0.315 + 0.012 - 0.004	0.484 ± 0.039

Company reserves the right to improve product design, functions and reliability without notice.

REV:A

Marking Code

Part Number	Marking Code
AMMST2907A-HF	K3F.

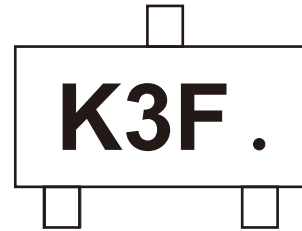

Suggested P.C.B. PAD Layout

SIZE	SOT-323	
	(mm)	(inch)
A	0.70	0.028
B	0.90	0.035
C	0.65	0.026
D	1.90	0.075

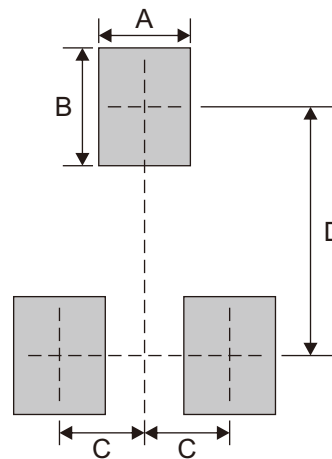

Note: 1. The pad layout is for reference purposes only.

Standard Packaging

Case Type	REEL PACK	
	REEL (pcs)	Reel Size (inch)
SOT-323	3,000	7